

## ULTRASOUND DEVICE FOR THE SCREENING OF COAGULATION

*Ushakova A.A.*

*Belorussian state university of informatics and radioelectronics  
P. Browki Str., 6, BSUIR, ETE dept., 220013, Minsk, Belarus  
E-mail: ushakova@bsuir.by*

Abstract. Currently in diagnostic laboratories there are three types of assays that measure the activities of individual coagulation factors: optical, electromechanical and electrochemical. However, all of the already existing devices have their limitations and disadvantages. In addition, some assays require additional preparative steps such as plasma separation. Therefore, it is obvious that a demand for devices which can test not only plasma, but also the whole blood is still exist.

During the experiments, it was discovered that it is possible to use ultrasound in coagulation monitoring [1]. It is proposed to develop device on the base of ultrasound coagulation screening method. This device could be applied for the prothrombin time (PT) and activated partial thromboplastin time (APTT) determination. On the basis of undertaken experiments and in accordance with the existing laboratory requirements this device should comply with the following requirements:

- internal mechanism for detecting clot formation;
- automated time measurement of the clotting endpoint;
- probing ultrasound signal at the 600 kHz frequency;
- internal device for maintaining constant 37 °C temperature;
- tests results in a user-friendly display format;
- ability to transmit data to the PC.

The main purpose of the ultrasound coagulation monitoring device is measuring of phase displacement between probing signal and the signal, which passed through the blood sample to detect a fibrin clot. Timer should be initiated upon addition of the reagents, which start the coagulation cascade. When a fibrin clot is formed, the path length of ultrasound waves' increase and the phase displacement appears. At this moment timer should be stopped. Then the clotting time will be calculated automatically and displayed.

The ultrasound coagulation monitoring device which meet all of the above mentioned requirements include the following blocks: oscillation generator unit, input/output stage, ultrasonic (US) probes, control unit, heating unit, power supply unit, input/output device.

The sine-wave oscillation unit can be built upon the popular Hartley circuit scheme (Figure 1). Hartley circuit is commonly used in oscillator applications and the recommended frequency range is from 20 kHz to 30 MHz. The oscillation frequency is determined by an inductor  $L_k$  and capacitor  $C_k$ . The frequency "F" of a Hartley oscillator can be expressed using the equation:

$$F = \frac{1}{2\pi \cdot \sqrt{L_k \cdot C_k}} \quad (1)$$

As we need frequency  $F = 600$  kHz we can calculate the  $L_k \cdot C_k$  product:

$$L_k \cdot C_k = \left(\frac{1}{2\pi F}\right)^2 = \left(\frac{1}{2 \cdot 3,14 \cdot 6 \cdot 10^{-5}}\right)^2 = 6,8 \cdot 10^{-14} \quad (2)$$

So in this case to provide 600 kHz frequency it is possible to use inductor  $L_k$  with the value 10  $\mu$ H and  $C_k$  with value 6,8 nF.

Resistors  $R_1$  and  $R_2$  give a potential divider bias for the transistor. Resistor  $R_e$  is the emitter resistor, which provides thermal stability for the transistor.  $C_e$  is the emitter by pass capacitors, which by-passes the amplified AC signal.

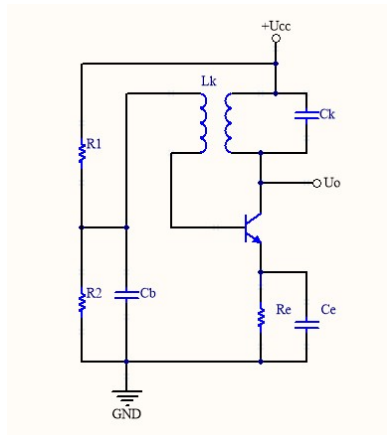

**Figure 1** - Hartley Oscillator Circuit

In the output stage generated AC signal pass through the emitter follower and pass-band filter. The emitter follower provides current and power gain of the signal. To meet the anticipated performance requirements we choose emitter follower with bipolar junction NPN transistor. After the emitter follower the AC signal passes through the pass band filter build on the operational amplifier (Figure 2). In the input stage should be an inverting amplifier based on the operational amplifier.

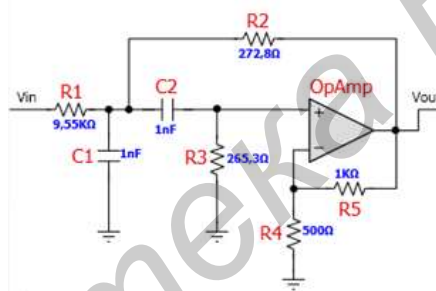

**Figure 2** – Second Order Chebyshev Filter

The microcontroller Cygnal C8051F040 can be used as a control unit. It combines a comprehensive set of analog and digital peripherals with Cygnal's High-Speed CPU and FLASH memory. The main purpose of the microcontroller in ultrasound coagulation monitoring device is to calculate phase displacement, fix the endpoint of coagulation cascade and count coagulation time. Also microcontroller can provide the data transmission to the PC as it has RS-232 interface. An interface unit provides communication between the monitoring device and the user. It includes the keyboard with control buttons and the LCD screen.

**Conclusions.** The use of ultrasound in coagulation monitoring could provide more accurate measurements in whole blood improve outcomes and reduce measuring time. It is possible to design ultrasound device for monitoring of coagulation process on the base of ordinary cheap and easily-accessible electronic components. Combining integrated-circuit technologies with the special microcontroller firmware provides a powerful platform for ultrasound monitoring device development. The possibility of transmission acquired data to the PC in this device would also be of benefit. It is provide an opportunity to create medical expert system on the base of ultrasound coagulation monitoring devices.

#### *References*

1. **Ushakova A. A.** The Principles of Ultrasound Coagulation Monitoring / A.A. Ushakova, V.M. Bondarik, O.V. Lanina. – IJSEAS, Volume 1, Issue 7, p. 285- 288.
2. **Hill W.** The art of electronics / W. Hill, P. Horowitz. – Cambridge university press. 1989, 1101 p.